



Designed &
manufactured
in **Italy**

FRENER REIFER

diviso_^{FR}

Glazed interior partitions
in exclusive design



diviso_{FR}

Sleek, elegant design
Maximum transparency
Highest quality

Suitable for offices, stores,
hotels and retail settings

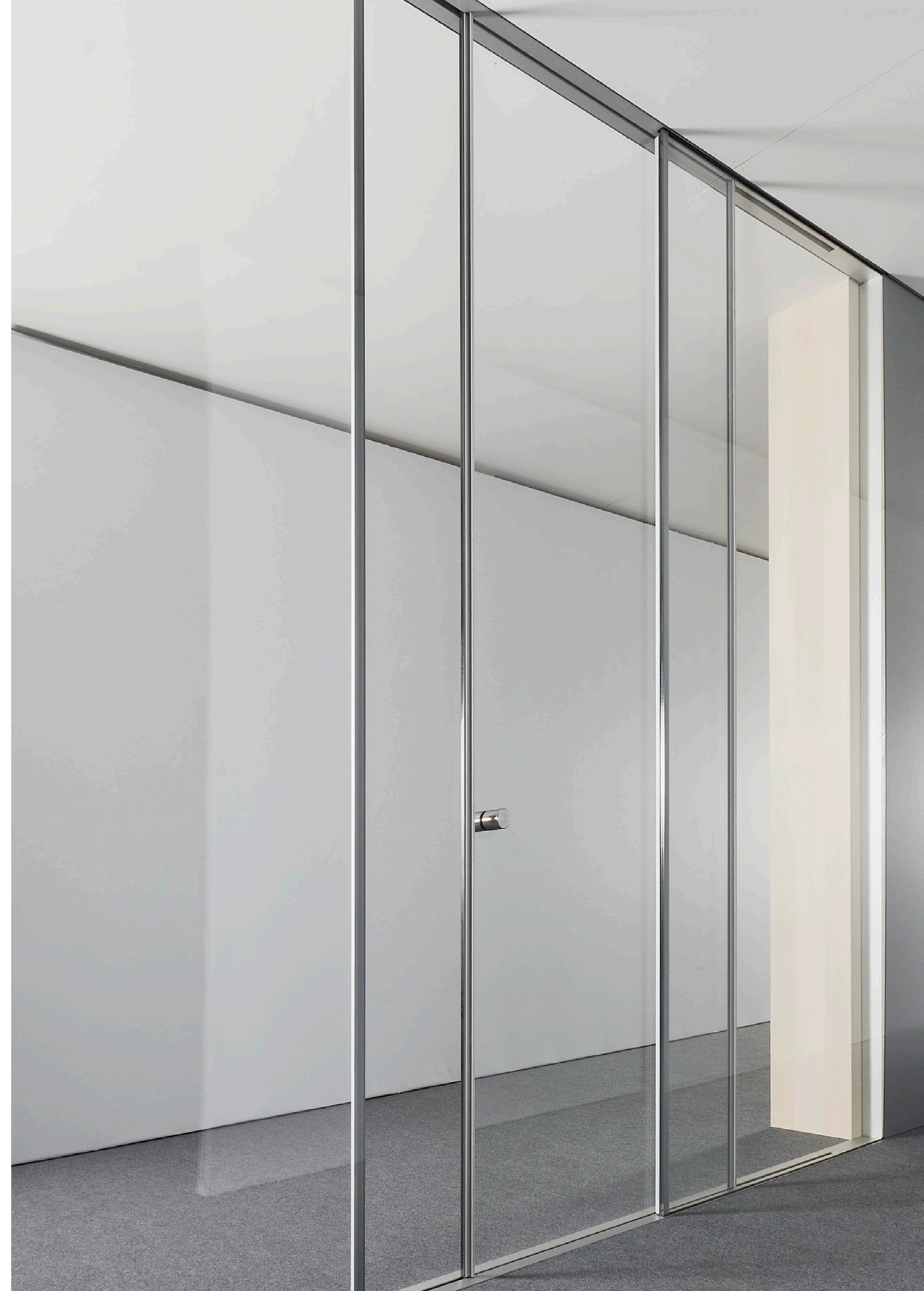



Design and quality
from the Italian Alps

diviso_{FR}

Partition wall systems from FRENER & REIFER

diviso_{FR} partition wall systems embody an elegant and contemporary design that fits seamlessly into any room concept. They open up a wide range of possibilities for architects and planners to design rooms with almost limitless transparency. The discreet aluminum frame blends harmoniously into the walls, floor and ceiling and creates a perfect balance between **unique aesthetics, elegant simplicity and precise functionality.**

50 years of experience make FRENER & REIFER the ideal partner for outstanding high-quality custom glass constructions. The partition wall system **developed in-house** adapts to individual requirements and offers customized solutions. Thanks to their filigree, modular design, our partitions are equally suitable for new builds and redesigns as well as for large or small spaces. **Professional advice, design flexibility and in-house production are guaranteed.**

FRENER & REIFER
HQ and Project Locations

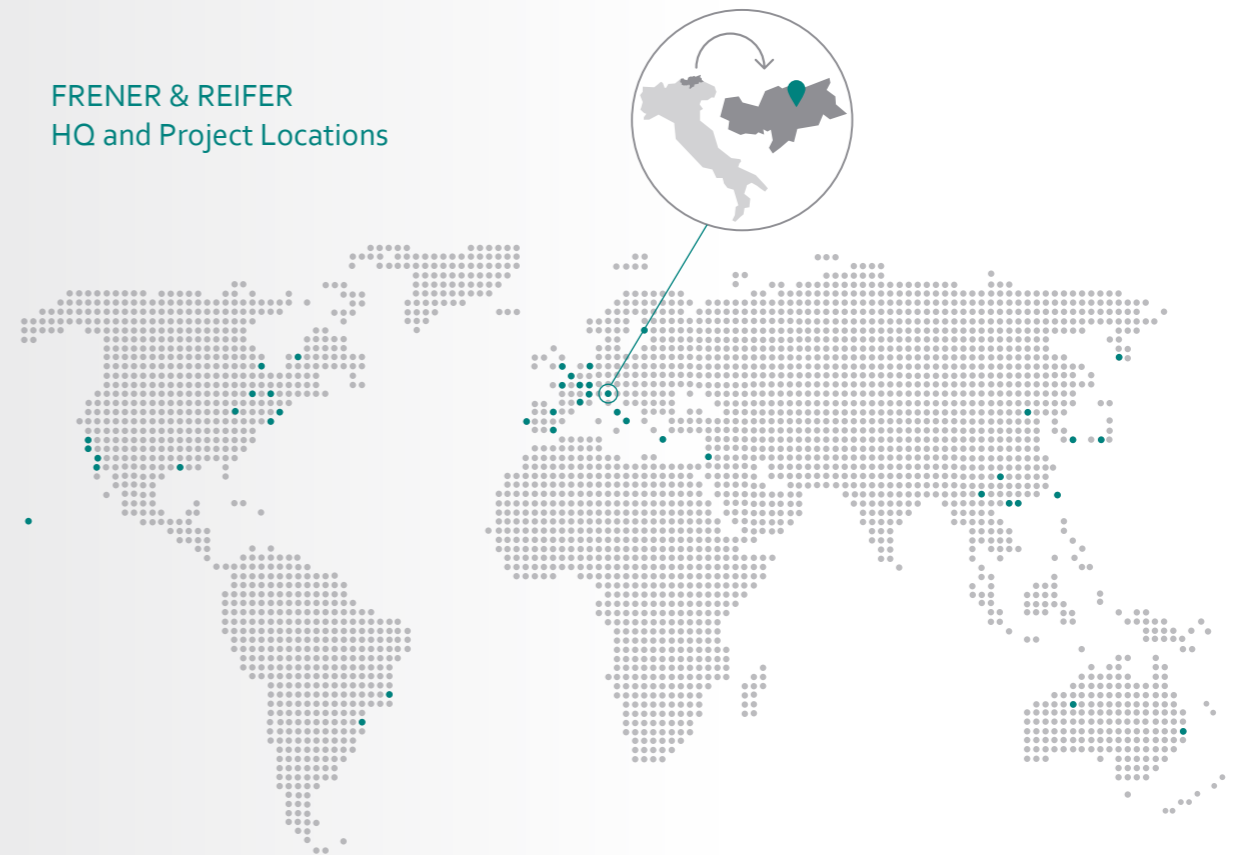

COMPLETE PACKAGE

For 50 years, FRENER & REIFER has been designing, fabricating and installing **custom constructions in glass, metal** and other materials for clients and investors to the designs of internationally renowned architects.

As a **full-service provider**, we accompany customers, architects and specialist planners through the entire process - from the consultation and PCSA phase through to fabrication, installation and subsequent after-sales services.

Our partners value our **solution-oriented flexibility** and the application of our **tireless inventive spirit** to every project task. True to our motto: „starting where the others stop“.



CONSULTATION & DESIGN



FABRICATION & INSTALLATION



MAINTENANCE & SERVICE



diviso_{FR} slide

with toughened glass (ESG) and sliding door

Our partition wall systems with single glazing impress with their versatility, combining maximum **elegance and transparency** with a **wide range of design options**.

Glazing

- » Monolithic toughened (ESG) or laminated (VSG) glass with PVB 0.76 mm
- » Pane thickness max. 12.76 mm
- » Design glass or white glass

Format

- » Fixed glazing grid dimensions up to max. 1500 mm, H 3400 mm
- » Sliding leafs up to max. W 2000 mm, H 3400 mm, weight up to 250 kg

Sound insulation

- » Up to 37 dB (laboratory value)



Customized
versions
on request



Design variants

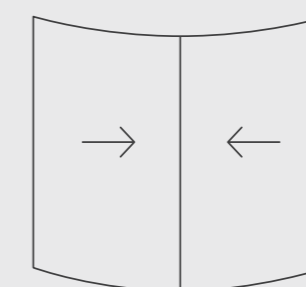
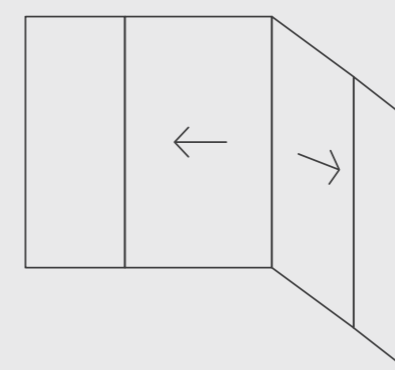
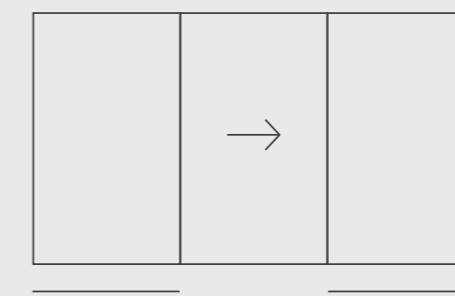
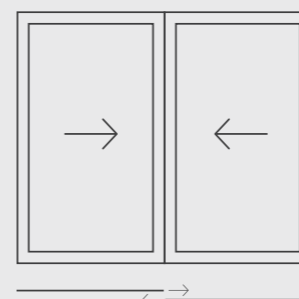
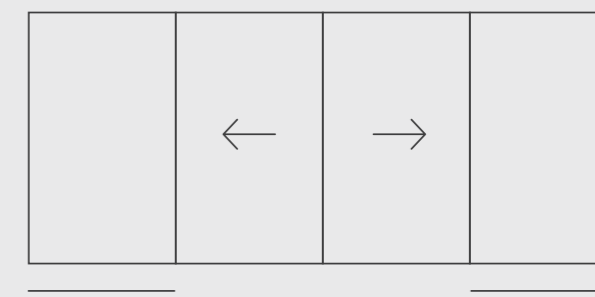
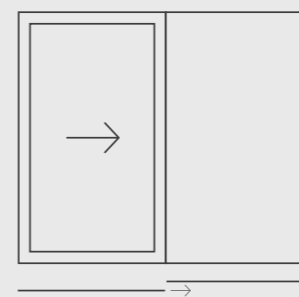



diviso _^{FR} pivot

Double glazing with safety glass and pivot door

The partition wall system for more privacy: the double glazing enables **higher sound insulation values** and the intermediate space offers an opportunity to integrate **anti-glare or privacy protection systems**.

Glazing

- » Double glazing in ESG or VSG with PVB 0.76 mm
- » Pane thickness according to design
- » Design glass or white glass

Format

- » Fixed glazing grid dimensions up to max. 1500 mm, H 3400 mm
- » pivoting leaf up to max. W 1500 mm x H 3000 mm, weight up to 150 kg

Sound insulation

- » Up to 47 dB (laboratory value)

Customized versions on request

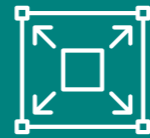

Execution

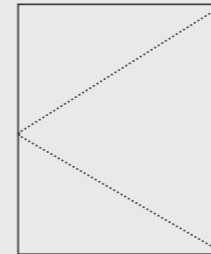



FRAMES AND PROFILES

diviso^{FR} features frames and profiles in high-quality aluminum. Their sophisticated design conveys a feeling of **lightness and spaciousness**, while the silicone-bonded all-glass walls create a particularly **sleek aesthetic**.

Narrow face widths

Slim profiles give every room a particularly elegant and light appearance.

Smooth-running guide system

Stainless steel runners and rails ensure easy, even and noiseless guidance of the sliding doors.

Accessibility

Flush-mounted guide rails integrated into the floor create barrier-free access and are also easy to clean.

Customized
versions
on request

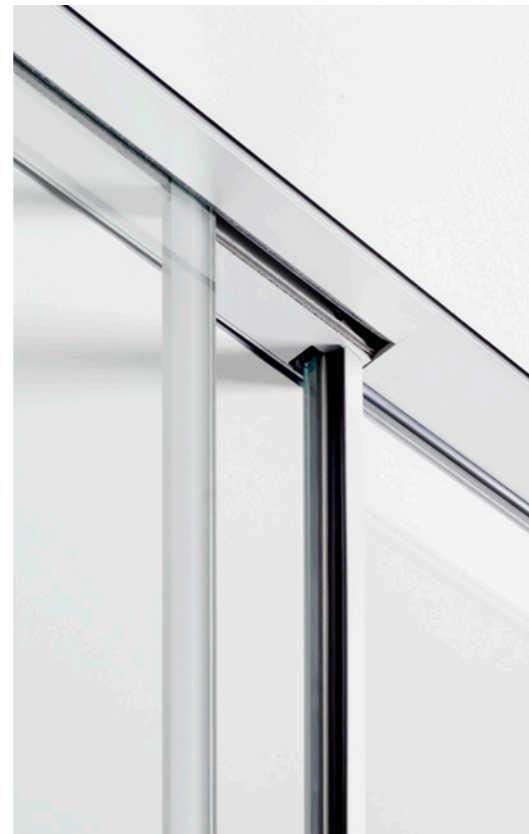
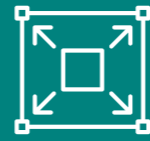

DESIGN

diviso^{FR} partition wall systems adapt to the individual ideas of customer and planner. The overall solution offers **maximum design freedom** and blends perfectly to create an elegant appearance.

Handle

- » Elegant and high-quality door knob or handle made of brushed stainless steel
- » Individual handle solutions on request

Surfaces

- » Glazing: any type of printing possible
- » Frame: powder-coated or anodized

Frame Colors

- » EV1 anodized shades
- » Others on request

Privacy and anti-glare protection

- » Material and model freely selectable for diviso^{FR} pivot

Customized
versions
on request

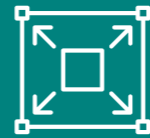

Technical data comparison

diviso ^{FR} slide Single glazing and sliding door

diviso ^{FR} pivot Double glazing and pivot door

Format		
Leafs (max. width x max. height)	2000 x 3400 mm	1500 x 3000 mm
Fixed glazing (grid dimension x max. height)	1500 x 3400 mm	2000 x 3400 mm
Leaf weight (max.)	250 kg	150 kg
Profile		
Material	Aluminium	Aluminium
Face width	According to structural requirements	According to structural requirements
Floor profile	Accessible	Accessible
Surface(s)	Powder-coated or anodized	Powder-coated or anodized
Color	EV1 anodized shades	EV1 anodized shades
Glazing		
	Monolithic glass ESG or VSG with PVB 0.76 mm	Double glazing in ESG or VSG with PVB 0.76 mm
	Pane thickness max. 12.76 mm	Pane thickness according to design
	Design glass or white glass	Design glass or white glass
	Any type of printing possible	Any type of printing possible
Sound insulation	Up to 37 dB (laboratory value)	Up to 37 dB (laboratory value)
Design		
Handles	According to choice	According to choice
Privacy and anti-glare protection	–	Can be integrated

CUSTOMIZED CONSULTING AND EXECUTION

Every diviso ^{FR} partition wall system can be further developed individually beyond the standard and adapted to specific requirements.

Whether XL special formats, extravagant design solutions or special surface treatments - we find a solution for every request.

FRENER & REIFER
Starting where the others stop

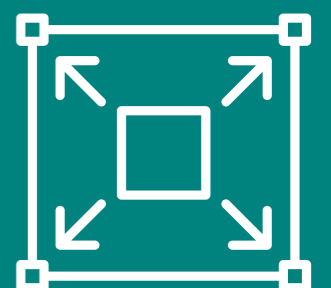

Vertical section

Horizontal section

diviso_{FR} slide

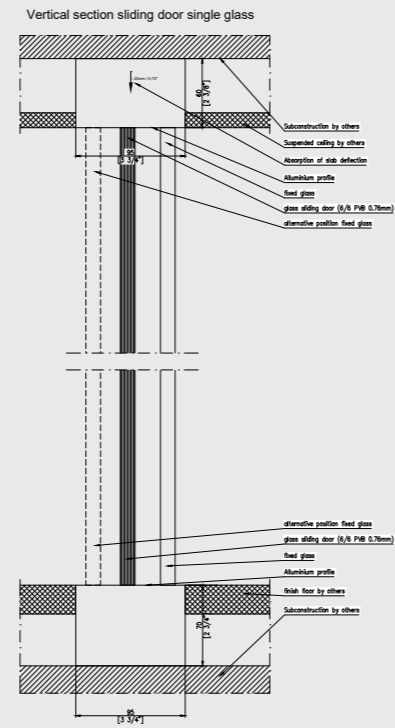

diviso_{FR} pivot

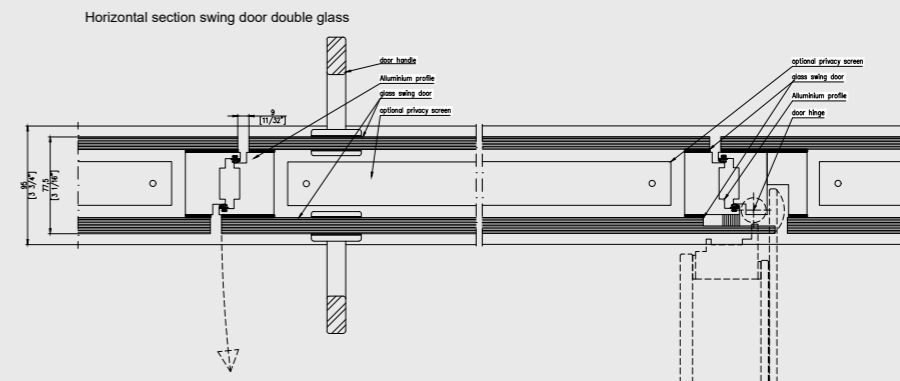
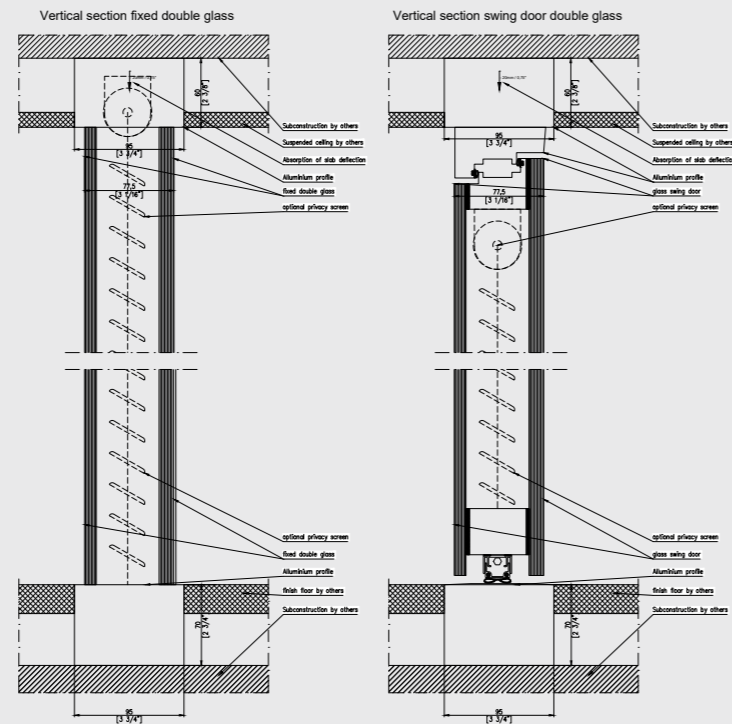

EXPERT CRAFTSMANSHIP
AND PRECISION
DOWN TO THE SMALLEST DETAIL.

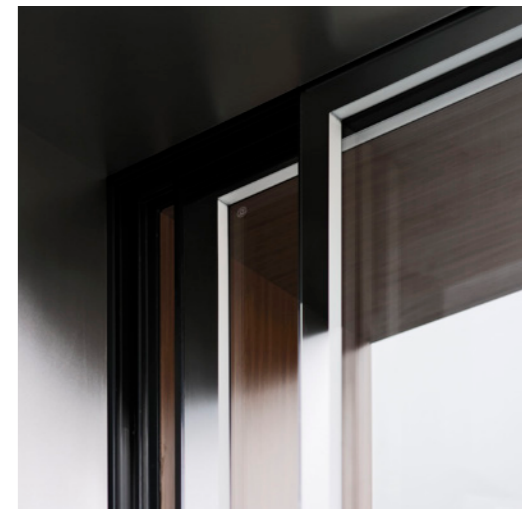

FRENER REIFER

FRENER & REIFER

New York
United States of America
phone +1 (646) 790 58 29
america@frenereifer.com

Contact person:
Marc Zimmer
mobile +1 (347) 445 96 56
zimmer@frenereifer.com